

Narragansett Imaging

DATA SHEET

XQ2172 Series
CAMERA TUBE

Narragansett Imaging
51 Industrial Dive
North Smithfield, RI 02876
Tel: (401) 762-3800
Fax: (401) 767-4407
www.nimaging.com

April 2001

25.4 mm (1 inch) diameter Plumbicon® television camera tubes with high-resolution lead-oxide photoconductive target, exclusively for use with X-ray image intensifiers with P20 output phosphor in medical equipment.

The XQ2172 series comprises the following versions:

- XQ2172/02 Rear loading, with target centering ring and standard anti-halation glass disk
- XQ2172/03 Front loading, with metal ring, and with standard anti-halation glass disk.
- XQ2172/03X Front loading, with metal ring and BG18 anti-halation glass disk.
- XQ2172/02A same as XQ2172/02 but no spots are allowed in Zone 1.

Special features are:

- New photoconductive target for increased resolution.
- “Diode” electron gun with special cathode for high beam current operation, improved beam acceptance and low lag.
- Provision for light bias to reduce lag.

QUICK REFERENCE DATA

“Diode” electron gun

Diameter	25.4 mm (1 in)
Length	approx. 170 mm
Focusing	magnetic
Deflection	magnetic
Useful target area, circle diameter	16.2 mm
Spectral response	see Fig. 3
Sensitivity with P20 light source	
XQ2172/02	typ. 490 μ A/lmF
XQ2172/03	typ. 490 μ A/lmF
XQ2172/03X	typ. 465 μ A/lmF
Resolution	typ. 60%
Heater	6.3 V, 190 mA

®Registered Trade Mark for television camera tube

OPTICAL DATA

Dimensions of quality area on photoconductive target circle, dia 16.2 mm.

Orientation of image on target

For correct orientation of the image on the target the vertical scan should be essentially parallel to the plane passing through the tube axis and the mark on the tube base.

Faceplate

Thickness	1.2 mm
Refractive index	1.49

Standard anti-halation glass disc (XQ2172/03)

Thickness	5 mm
Refractive index	1.52

BG18 anti-halation glass disc (XQ2172/03X)

Thickness	1.07 mm
Refractive index	1.54

ACCESSORIES

Socket type 56605

Deflection and focusing coil unit,

XQ2172/02	AT1126/03S
XQ2172/03, XQ2172/03X	AT1116S

ELECTRICAL DATA

Deflection magnetic

Focusing magnetic

Heating

Indirect by a.c. or d.c.

Heater voltage	V_f	6.3 V \pm 5%
----------------	-------	----------------

Heater current, at $V_f = 6.3$ V	I_f	190 mA
----------------------------------	-------	--------

The heater voltage must not exceed 9.5 V r.m.s. For optimum performance stabilization of the heater voltage is recommended.

Capacitance

Signal electrode to all

XQ2172/02	2.5 to 4 pF
-----------	-------------

XQ2172/03, XQ2172/03X	3 to 5 pF
-----------------------	-----------

These capacitance's, which are effectively the output impedance's, increase when the tubes are inserted in the coil unit.

LIMITING VALUES (Absolute maximum rating system)

All voltages are referred to the cathode, unless otherwise stated.

Notes

Signal electrode voltage	V_{as}	max.	50 V	
Grid 4 voltage (mesh)	V_{g4}	max.	1100 V	
Grid 3 voltage	V_{g3}	max.	800 V	
Voltage between grid 4 and grid 3	$V_{g4/g3}$	max.	450 V	
Grid 2 voltage	V_{g2}	max.	350 V	
Grid 1 voltage, positive	V_{g1}	max.	20 V	1
Grid 1 voltage, negative	$-V_{g1}$	max.	200 V	
Grid 1 current (\approx cathode current)	I_{g1}	max.	10 mA	3
Cathode to heater voltage, positive peak	V_{kfp}	max.	50 V	
Cathode to heater voltage, negative peak	$-V_{kfp}$	max.	125 V	
Cathode heating time before drawing cathode current	t_h	min.	1 min	
External resistance between cathode and heater at $V_{kfp} > 10$ V	R_{kf}	min.	2 k Ω	
Ambient temperature, storage and operation	T_{amb}	max. min.	50 °C -30°C	
Faceplate temperature, storage and operation	T	max. min.	50 °C -30°C	4
Faceplate illuminance	E	max.	500 lx	5

OPERATING CONDITIONS AND PERFORMANCE

Notes

Conditions

6

Cathode voltage	V_k	0 V	
Signal electrode voltage	V_{as}	45 V	
Beam current	I_b		2,7,8
Grid 4 voltage	V_{g4}	960 V	9
Grid 3 voltage	V_{g3}	600 V	9
Grid 2 voltage	V_{g2}	300 V	
Grid 1 voltage	V_{g1}	0 to 20V	
Blanking voltage on grid 1, peak to peak	$V_{g1\ p-p}$	30 V	
Focusing coil current			6
Deflection and alignment currents			6
Faceplate illuminance (P20 light source)	E	0 to 10 lx	
Faceplate temperature	T	20 to 45 °C	

Electron Gun Characteristics

Grid 1 voltage for cut-off at $V_{g2} = 300V$	V_{g1}	-10 to 0 V
Grid 1 voltage for normal beam setting	V_{g1w}	≤ 20 V
Grid 1 current at normally required beam currents	I_{g1}	≤ 5 mA
Grid 2 current at normally required beam currents	I_{g2}	≤ 0.1 mA
Blanking voltage, peak to peak, with respect to V_{g1w}	$V_{g1\ p-p}$	30 V

Performance

Dark current	I_d	< 2 nA	
Sensitivity at colour temperature of 2856K			10
XQ2172/02	min. 440	typ. 490 μ A/lm	
XQ2172/03	min. 440	typ. 490 μ A/lm	
XQ2172/03X	min. 400	typ. 465 μ A/lm	
Sensitivity with P20 light source			
XQ2172/02	min. 145	typ. 155 μ A/lmF	
XQ2172/03	min. 145	typ. 155 μ A/lmF	
XQ2172/03X	min. 90	typ. 110 μ A/lmF	
Peak signal current with E=1 lx (P20)			11
XQ2172/02	I_{sp} min. 210	typ. 225 nA	
XQ2172/03	I_{sp} min. 210	typ. 225 nA	
XQ2172/03X	I_{sp} min. 185	typ. 215 nA	
Peak signal current (16.2 mm dia scanning)		2000 nA	7

			Notes
Gamma of transfer characteristic	0.95 ± 0.05		
Spectral response:	see Fig. 3		
Resolution			12
Modulation depth i.e. uncompensated amplitude response at 20.3 lp/mm (scanned area 9.6 x 12.8 mm) at the centre of the picture (5 Mhz, 400 TV lines)	min. 50%	typ. 60%	
Modulation depth at 12 lp/mm (scanned area 16.2mm diameter) at the centre of the picture (5MHz, 400 TV lines)	min. 70%	typ. 80%	
Modulation transfer characteristic	see Fig. 4		
Residual signal after dark pulse of 50 ms	max. 22%	typ. 15%	13,14
Residual signal after dark pulse of 60 ms	max. 18%	typ. 12%	13,14
Residual signal after dark pulse of 200 ms	max. 7 %	typ. 4.5%	

NOTES

1. The “Diode” gun operates with a positive grid 1 voltage, hence draws some grid current. The grid 1 voltage (d.c.) must be adjusted for correct beam current as described in note 8.
2. “Diode” gun is a triode gun operating in a diode mode, providing a very high beam reserve. Continuous operation with a high beam setting is to be avoided since this will shorten tube life. High I_b settings should be used under high light intensity conditions only. All other modes of operation should be normal I_b settings or have then cut off.
3. A current limiter must be incorporated to limit total cathode current to 10 mA maximum.
4. The tube can withstand short excursions up to 70 °C without any damage or irreversible degradation in performance.
5. For short intervals. During storage the tube face shall be covered with the plastic hood provided; when the camera is idle the lens shall be capped, in stand-by also the beam will be cut-off.
6. The operating conditions and performance data quoted relate to operation of the tube in coil units AT1116 or AT1126. See relevant data of deflection/focusing assemblies. Scanning amplitude should be adjusted such that the useful target area of 16.2-mm dia. is displayed on a standard monitor as a circular area with a diameter equal to the raster height.
7. The maximum peak signal which can be handled is 3 μ A. Video amplifiers should be designed to accommodate this.
8. The beam current I_b as obtained by adjusting the control grid voltage (grid 1) is set at 400 nA. I_b is not the total current available in the scanning beam, but is defined, as the maximum amount of signal current I_s , that can be obtained with this beam. In the performance figures, e.g. for resolution and lag, the signal current and beam current conditions are given, e.g. as $I_s/I_b = 20/300$ nA. This means: with a signal current of 20 nA and a beam setting which just allows a signal current of 300 nA.

N.B. The signal currents are measured with an integrating instrument connected in the signal electrode lead and a uniform illumination of the scanned area. See note 11.

9. The optimum voltage ratio V_{g4}/V_{g3} to minimize beam-landing error (preferable ≤ 1 V) depends on the type of coil unit used. For types AT1116 and AT1126 a ratio of 1.6 is recommended. Grid 4 (mesh) should under no circumstances be allowed to operate at a voltage below that of grid 3 as that might damage the target.
10. Measuring conditions: illuminance level 4.54 lx at a colour temperature of 2856K and filters Schott VG9 and Calflex B1/K1 inserted in the light path.

Notes (continued)

11. The peak signal currents are measured on a waveform oscilloscope and with a uniform illumination on the 16.2-mm ϕ target area.
When measured with an integrating instrument connected in the signal-electrode lead the average signal currents will be smaller:
 - a) By a factor α ($\alpha = \frac{100-\beta}{100}$), β being the total blanking time in %; for the CCIR system α amounts to 0.75; for the EIA system α amounts to 0.83.
 - b) By a factor δ , δ being the ratio of the active target area (circle with: 16.2 mm ϕ) to the area which would correspond with the adjusted scanning amplitude (16.2 mm x 21.6 mm) this ratio amounts to $\delta = 0.59$.
The total ratio of integrated signal current, I_s , to the peak signal current, I_{sp} , amount to $\alpha \times \delta = 0.44$ for the CCIR system and 0.49 for EIA system.
12. As measured with a 50 mm Leitz Summicron lens having a sine response of approximately 85 % at 400 TV lines at f: 5.6. The published 60% typ. is uncorrected. Tube resolution is higher. Measured with 200 nA signal current and a beam current just sufficient to stabilize a signal current of 400 nA. The horizontal amplitude response can be raised by means of suitable correction circuits, which affect neither the vertical resolution nor the limiting resolution.
13. Measured with a 20 nA signal current and a beam current just sufficient to stabilize a signal current of 300 nA.
14. Decay lag. After a minimum of 5 s of illumination of the target. Values shown relating to decay lag represent the residual signal currents in percentages of the original signal current as a function of time, after the illumination has been removed.

Diagrams

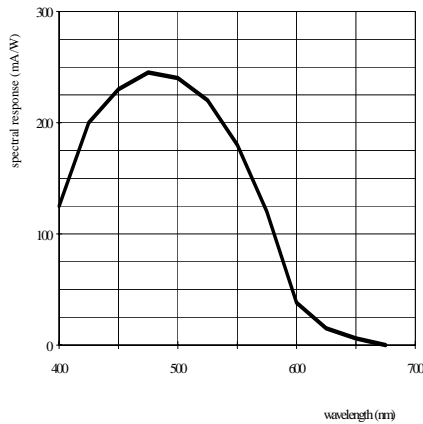

3 Typical spectral response curve.

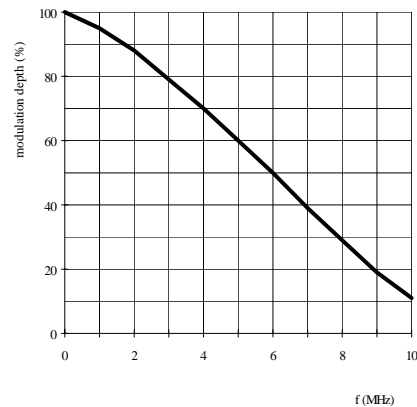
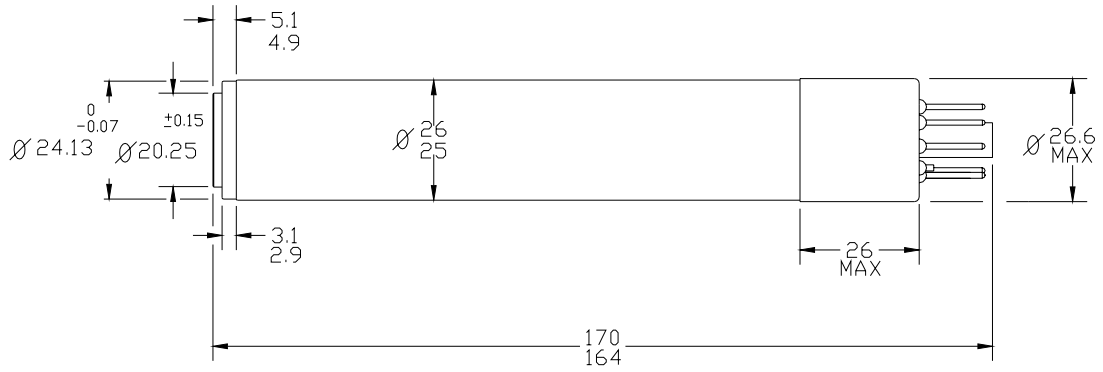

Fig. 4 Typical square-wave response curve.

Fig.

Mechanical Data

Rear loading tubes XQ2172/02



Front loading tubes XQ2172/03

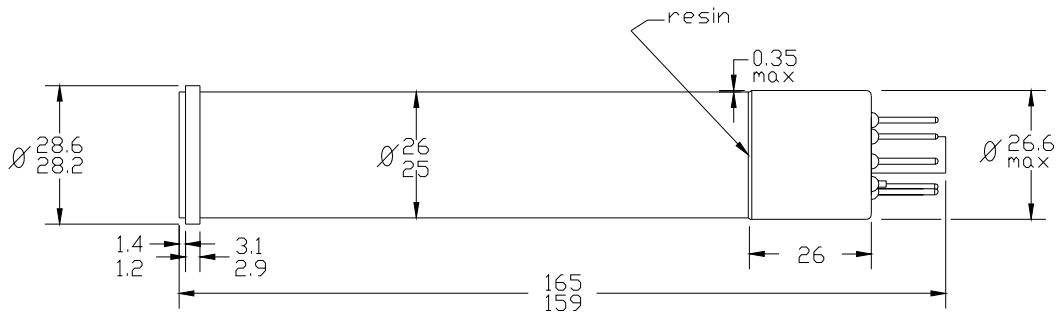

Front loading tubes XQ2172/03X

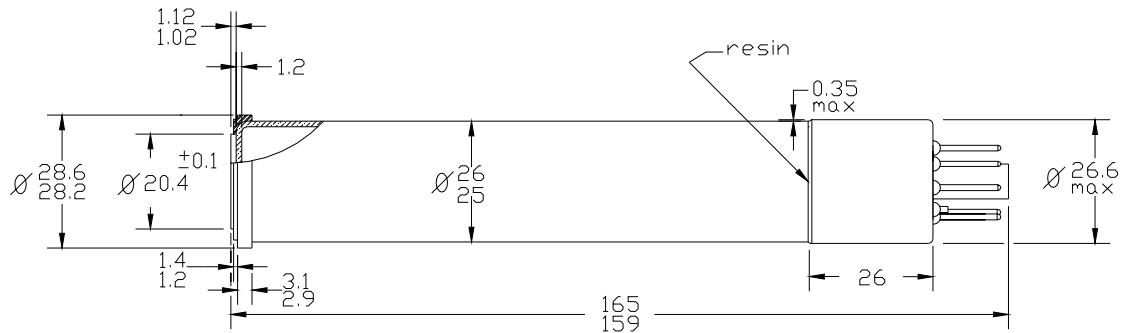

Figure 1.

Mounting Position: any

Mass: ≈ 70 g

Base: IEC 67-I-33a (JEDEC E8-11)

Mechanical Data

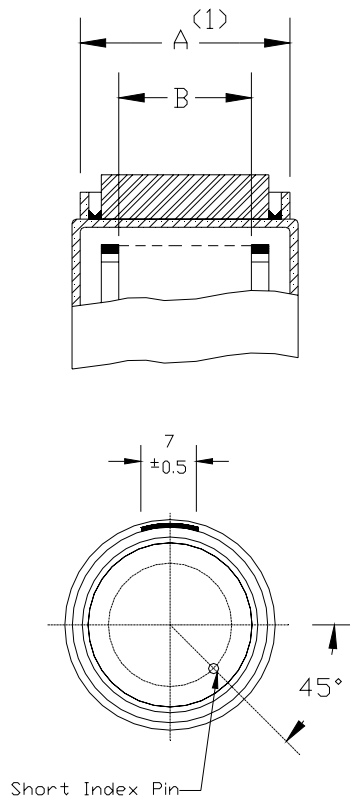

FRONT VIEW
XQ2172/02
Figure 2

(1) The distance between the geometrical centers of diameter A of the reference ring and diameter B of the mesh electrode ring is $< 100 \mu\text{m}$.

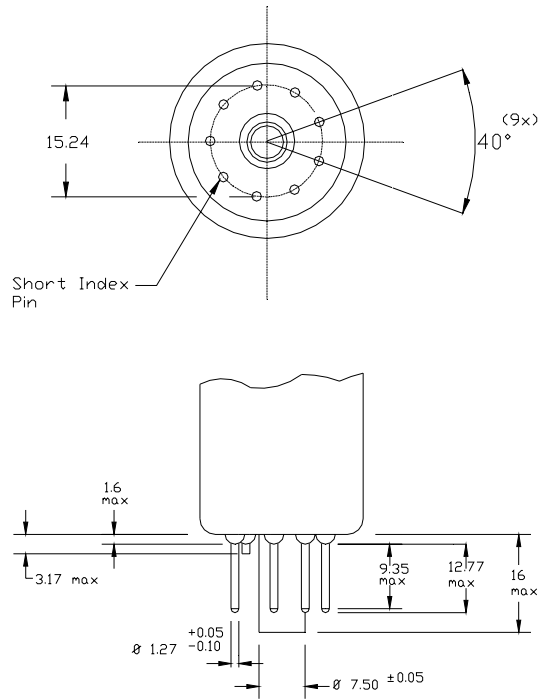

Figure 2a

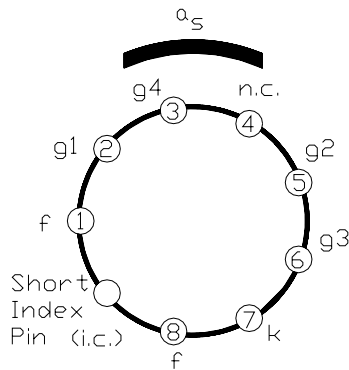

Figure 2b

For more information contact:

Narragansett Imaging

Don Browne

Vice President, Camera Tubes

51 Industrial Drive

North Smithfield, RI 02896-2078

Tel: (401) 762-3800

Fax: (401) 767-4407

www.nimaging.com